

Antares 40

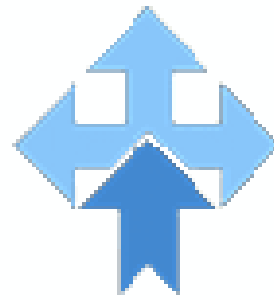

PIANA
compressed
air

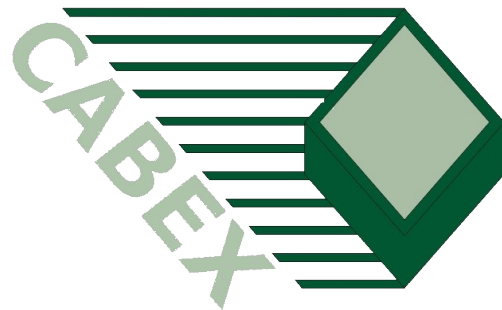

MATERIALS USED

- Diecast body of UNI 3715 alloy.
- Cups and drips-trais of GRILAMID high-resistance, shock-proof and splinter-proof, transparent plastic.
- Other parts are of DELRIN - ABS - NYLON V. and BRASS.
- Compensating springs are made of C72 STEEL and are locked, calibrated and tropicalized.

CONNECTIONS

- 1/4".

FITTING

- Wall fitted by means of screws directly on the units or with brackets to be applied on the regulator.

PRESSURE

- Max 12 bar / 170 PSI.

TEMPERATURES

- Max 50° C / 120° F.

SURFACE FINISHING

- All the alloy components are treated, after manu-facturing, with oxideproofing and chrome plating, and lastly epossidic enamel stoved.

FLOW CHART

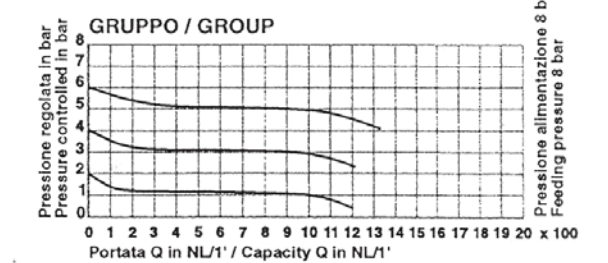
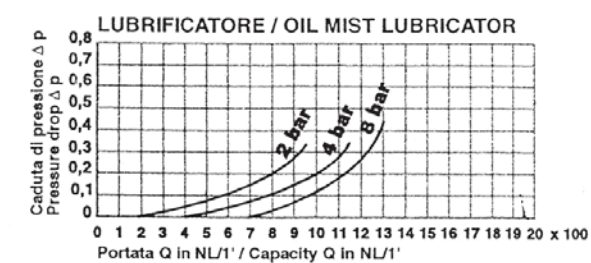
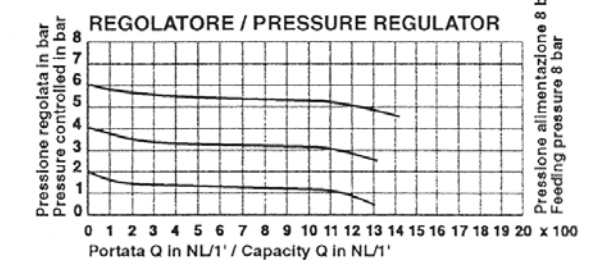
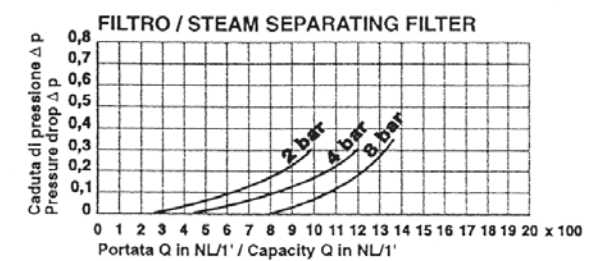

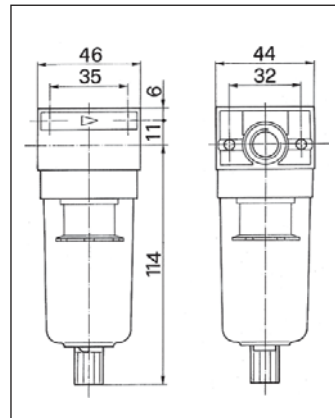

F40 STEAM SEPARATOR FILTER 42111503

Connectors 1/4" gas
 Cup capacity 50 cc
 Impurity zone - Bereich für Schmutz 25 cc
 Filtration degree - Filterfähigkeit 40 µ
 Weight 235 g

Series semi-automatic drain

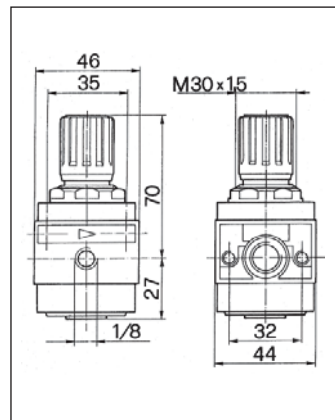

R40 PRESSURE REGULATOR 42131513

Connectors 1/4" gas
 Input pressure max 24 bar
 Output pressure 0 ÷ 12 bar
 Weight 320 g

R40 SM PRESSURE REGULATOR WITHOUT GAUGE 42131503

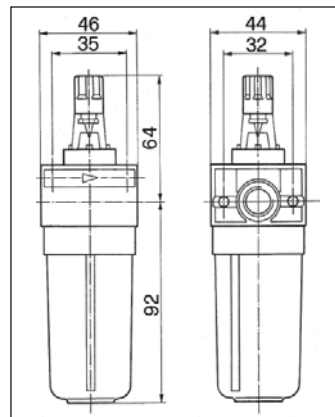

L40 OIL-MIST LUBRICATOR 42121503

Connectors 1/4" gas
 Cup capacity 50 cc
 Max oil level 40 cc
 Weight 245 g

LUBRICANTS ADVISED
 (Viscos. 2° E a 50°C)

- BP ENERGOL HLP 22
- SHELL TELLUS 22
- ESSO SPINESSO
- MOBIL 22 DTE 22

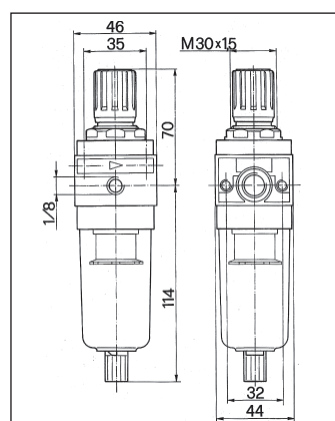

FR40 PRESSURE FILTER-REGULATOR 42141513

Connectors 1/4" gas
 Cup capacity 50 cc
 Impurity zone 25 cc
 Filtration degree 40 µ
 Input pressure max 24 bar
 Output pressure 0 ÷ 12 bar
 Weight 350 g

FR40 SM PRESSURE FILTER-REGULATOR WITHOUT GAUGE FILTER 42141503

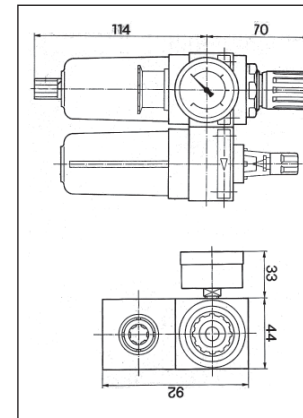

FR+L 40 TWO-UNIT COMPLETE GROUP

Connectors 1/4" gas
 Weight 610 g

ASSEMBLY BY:

- FR40 Pressure filter regulator
- L40 Oil-mist lubricator

FR+L 40 SM TWO-UNIT COMPLETE GROUP WITHOUT GAUGE 42103503

FR+L 40 TWO-UNIT COMPLETE GROUP WITH GAUGE 42103513

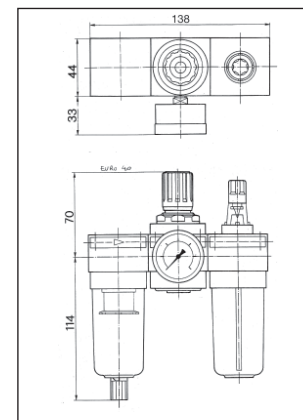

FRL 40 THREE-UNIT COMPLETE GROUP

Connectors 1/4" gas
 Weight 820 g

ASSEMBLY BY:

- F40 Steam separator filter
- R40 Pressure regulator
- L40 Oil-mist lubricator

FRL 40 SM THREE-UNIT COMPLETE GROUP WITHOUT GAUGE 42103003

FRL 40 THREE-UNIT COMPLETE GROUP WITH GAUGE 42103013

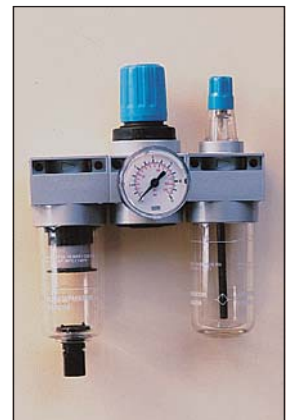

RICAMBI - ACCESSORI - ZUBEHÖR

BRACKET FOR R40/50	32100093
PLASTIC RING NUT R40/50	37100491
BOWL F40 COMPLETE	29521201
BOWL L40	27402801
BOWL WITH PROTECTION COMPLETE F40	29521301
BOWL WITH PROTECTION COMPLETE L40	29521401
PLASTIC PLAQUE FL40	37101301
PLASTIC SCREW COVER F/R/L 40	37101321
OR 115	37302131

WARNING • The units must not be exposed to exhalations or be directly in contact with corrosive or flammable liquids: the transparent parts would be damaged. To clean cups use water and common household detergents. Unappropriate oils deteriorate the transparent material on the lubricator and the components downstream. Use only oils as specified.